

<- Back

Forward ->

Document ID# 865452
2003 Chevrolet Chevy Suburban - 4WD

Print

Rear Wheel Steering Control Module Replacement

[Removal Procedure](#)

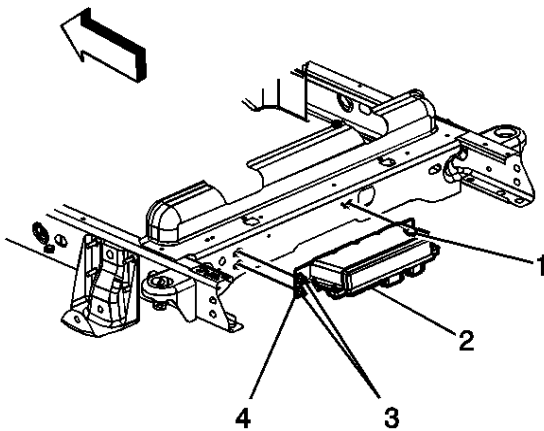

1. Raise the vehicle. Refer to [Lifting and Jacking the Vehicle](#) in General Information.
2. Disconnect the electrical connector from the control module.
3. Remove the nuts retaining the control module (2) to the bracket.
4. Remove the control module from the bracket (4).

[Installation Procedure](#)

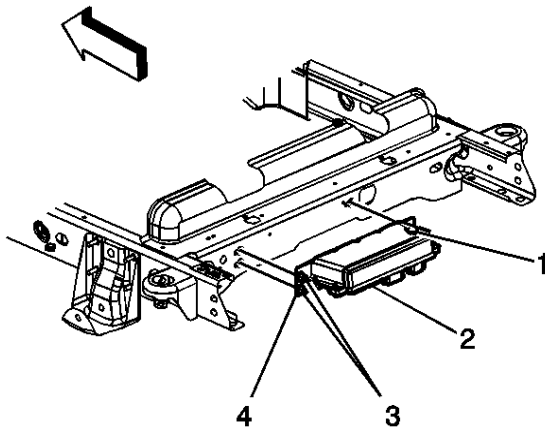

1. Install the control module (2) to the bracket.

Notice

Refer to [Fastener Notice](#) in Cautions and Notices.

2. Install the nuts retaining the control module to the vehicle. **Tighten**

Tighten the control module retaining nuts to 25 N·m (18 lb ft).

3. Connect the electrical connectors to the control module.
4. Program the control module. Refer to [Service Programming System \(SPS\)](#) in Programming.
5. Perform a learn alignment. Refer to [Measuring Wheel Alignment](#) in Wheel Alignment.

<- Back

Forward ->

Document ID# 865452
2003 Chevrolet Chevy Suburban - 4WD

Print